

3 Axis CNC Driver

Description:

Controls 3 Unipolar Stepper Motors, for use with CNC Machines. Simple driver with automatic coil shutdown, to ensure efficient operation. Opto-isolated for protection of the P.C. Supports most parallel port based CNC software.

Features:

- Full Stepping
- 3 Axis
- Toggle automatic coil shutdown
- Parallel Port Interface
- Opto-Isolated for PC protection
- Bare PCB supports upwards of 2 Amp per coil
 - Can be increased by coating power rails with solder
- Low part Count
- Easy to Solder
- 5, 6 or 8 wire Unipolar motors supported

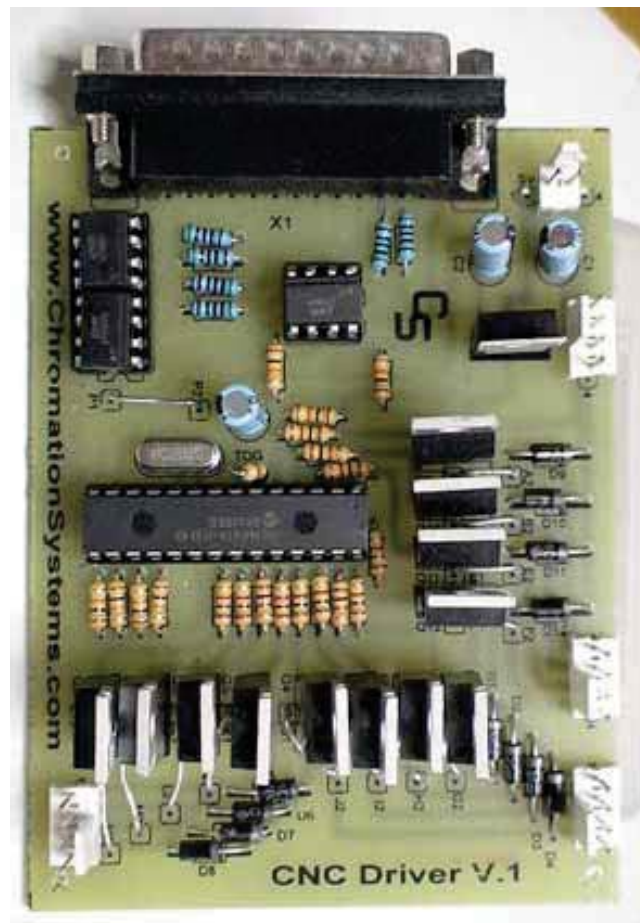

Specification:

Input Voltage	6v-24v
Input Amp for logic	< 200 ma
Input Amperage Total	depends on motors
Connectors	0.1" Pitch
Dimension	4"x3"x1"

**For More Kits & Projects Visit:
www.Chromationsystems.com**

3 Axis CNC Driver

R1 - R12	1kohm 1/4w	MOSFET pull-up
R13 - R19	10kohm 1/4w	Input pull-up
R20 - R25	~500 ohm 1/4w	Opto Current Limit
D1 - D12	1n4004 or better	Clamp Back EMF
TOG	10kohm 1/4w	Auto-Shutdown pull-up
XTAL	20mhz, series	Oscillator
SV1	4 Pin Header	Y Axis
SV2	4 Pin Header	X Axis
SV3	4 Pin Header	Z Axis
SV4	4 Pin Header	Power Input
SV5	4 Pin Header	Motor Positive Supply
OPTO	LTV-827	Isolation from PC
OPTO2	LTV-827 x2	Isolation from PC
C1 & C2	10uF Electrolytic	Decoupling
C3	1uF Electrolytic	Decoupling
IC2	7805	voltage regulation
Q1 - Q12	MOSFETs	Switches Power to motor
PIC16F870	PIC Microcontroller	Logic

Not Listed:

- Jumper Wires
 - Interconnect Housings
 - Interconnect crimps
 - 1x 28 pin socket
 - 1x 16 pin socket
 - 1x 8 pin socket
- Socket requires Pin 6 to be removed see Fig 1a & 1b

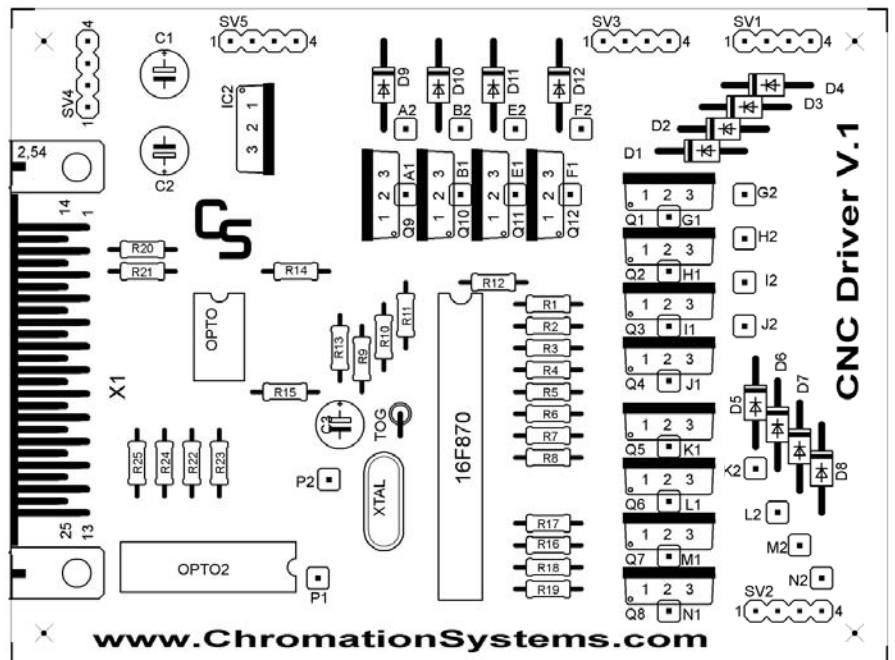

3 Axis CNC Driver

Fig. 1a

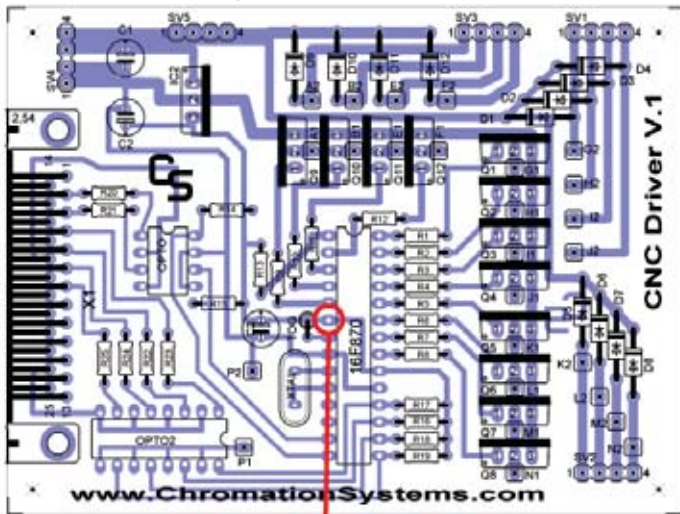

RA4 - not used, pull the pin out from the PIC's socket

Fig. 1b



A trace is routed through the pin, so its best to remove the socket's Pin 6 to prevent RA4 on the PIC from being affected.

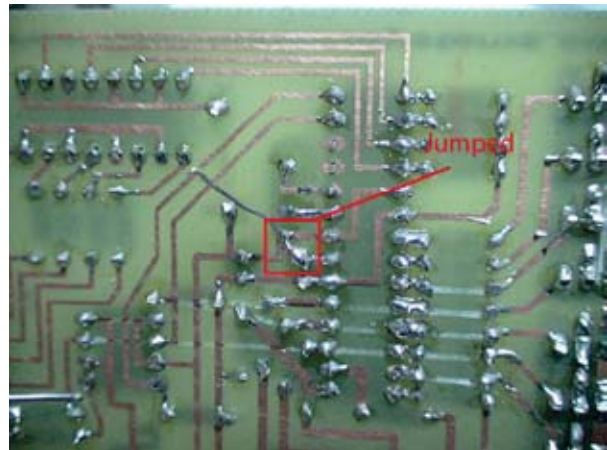
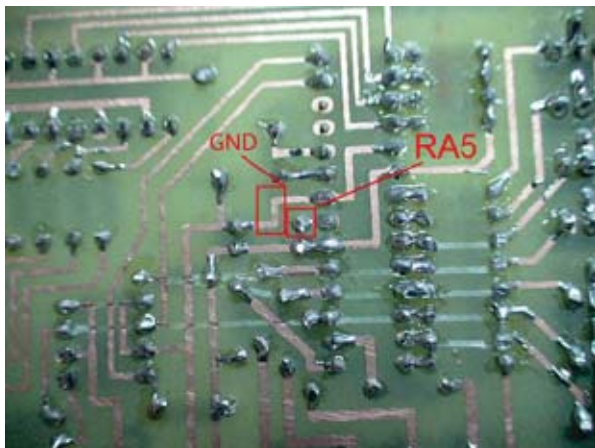

To toggle off the auto-shutdown feature, RA5 needs to be connected to GND by a jumper. If left un-jumped a motor will have all its coils turned off after ~50ms. See above Images.

Software Setup, pins are referenced to a male DB-25

X Step - Pin 4

Y Step - Pin 6

Z Step - Pin 2

X Direction - Pin 5

Y Direction - Pin 7

Z Direction - Pin 3